

QuickShot™

3A9322B

EN

For repair of QuickShot sprayers.



Important Safety Instructions

Read all warnings and instructions in this manual, on the unit, and in the battery and charger manual before using the equipment. Be familiar with the controls and the proper usage of the equipment. Save these instructions.



Important Medical Information

Read the medical alert card provided with the gun. It contains injection injury treatment information for a doctor. Keep it with you when operating the equipment.

Maximum Working Pressure: 2000 psi (138 bar, 14MPa)

Replacement Kits	Part No.	
Enclosure Cover	18H083	page 5
Pump Assembly	18H072	page 6
Prime/Spray Valve and Knob	2000079	page 7
Outlet Valve	18H075	page 8
SmartControl and Enclosure	18H076	page 9
Hose	2000354	page 10
Needle Valve	18H056	page 11
Solenoid, Pot, Trigger, Switch	18H057	page 11
Gun Housing	18H058	page 11
Complete Gun	18H059	page 11
Solvent Gasket	18H126	page 15

Related Manuals

Manual in English	Description
3A9301	QuickShot Owners manual
	DeWALT charger manual

Assembly Drawing

 Torque to 18 ± 5 in-lbs
(18 ± 0.6 N·m)

 Torque to 55 - 65 in-lbs
(6.2 - 7.3 N·m)

 Torque to 15 - 20 in-lbs
(1.7 - 2.3 N·m)

 Torque to 100 in-lbs
(11.3 N·m)

 Torque to 9 - 11 in-lbs
(1.0 - 1.2 N·m)

 Torque to 10 - 15 in-lbs
(1.1 - 1.7 N·m)

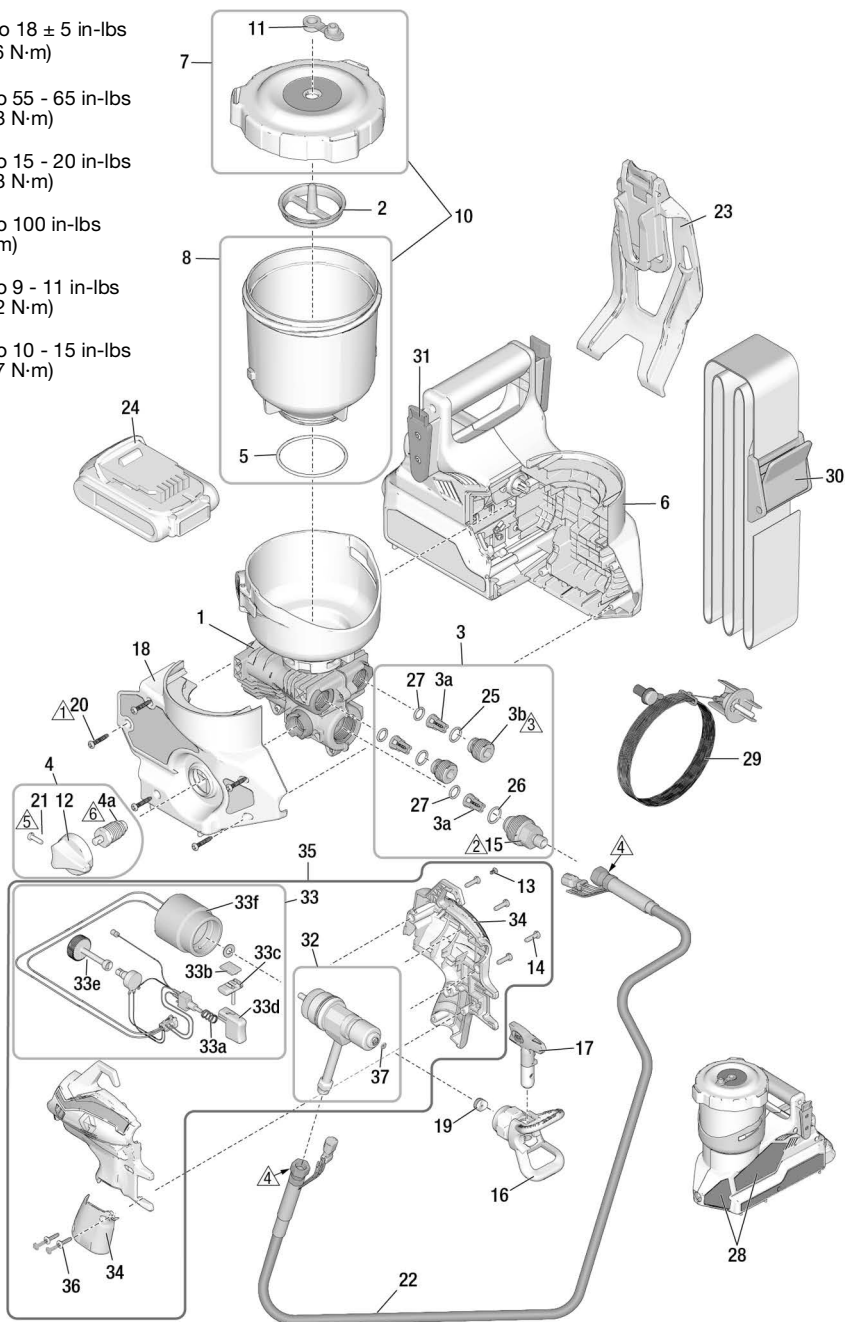

Assembly Drawing Parts List

Ref.	Order Part No.	Description
1	18H072	Kit, pump assembly, <i>includes 3, 4</i>
2	18H073	Kit, filter, 60 mesh, 3 pack
	18H074	Kit, filter, 100 mesh, 3 pack
3	18H075	Kit, outlet valve repair, <i>includes 3 of 3a, 2 of 3b, 2 of 25, 1 of 26, 3 of 27, 1 of 15</i>
3a		Outlet valve assembly
3b		Outlet valve plug
4	2000079	Prime/Spray valve and knob, <i>includes 4a, 12, 1 of 21</i>
4a		Prime valve
5	19F703	O-ring
6	18H076	Kit, control, enclosure, <i>includes 18, 28</i>
7	18H077	Kit, lid, plug, label
8	18H078	Kit, cup, 32 oz. <i>includes 5</i>
10	18H079	Kit, cup, lid, plug, o-ring, label, <i>includes 7, 8</i>
11	18H080	Kit, plug, 3 pack
12	17M882	Prime knob
13	19F832	Screw, torx
14	119236	Screw, torx
15	2000209	Kit, hose adapter
16	246215	Guard, spray tip, FFLP
17	FFLP514	Spray tip
	FFLP210	Spray tip
	FFLP410	Spray tip
18	18H083	Kit, enclosure, door, <i>includes 5 of 20</i>
19	17P501	Kit, tip seat and seal, 5 pack
20	18H096	Screw, cross-head
21	128726	Screw, cross-head
22	2000354	Kit, hose
23	18F977	Holster
24*		Li-ion Compact Battery Pack DEWALT
	17P474	20V 2.0 Ah - USA
	17P557	18V 2.0 Ah - Europe/AP
	17P556	18V 2.0 Ah - Japan
	17P558	18V 2.0 Ah - ANZ
	17Y586	18V 2.0 Ah - Korea
	17M883	Case, storage (not shown)
25	17T582	O-ring
26	117724	O-ring
27	18D981	O-ring
- - -	243103	Pump Armor, 4 oz (not shown)

Ref.	Order Part No.	Description
28▲	18H084	Kit, warning labels
▲		Medical alert card (not shown)
	17R476	English, Spanish, Portuguese (Brazil)
	17A134	English, Chinese, Korean
	179960	English, Spanish, French
	17F690	Dutch, German, Italian
29	18H085	Kit, ground
30	18F891	Belt
31	18F810	Adapter, belt slide
32	18H056	Kit, needle valve, <i>includes 1 of 37</i>
33	18H057	Kit, solenoid, pot, trigger, switch
33a		Spring, gun
33b		Spring, plastic, sliding
33c		Slide, lock, trigger
33d		Cap, trigger
33e		Knob, adjustment
33f		Solenoid
34	18H058	Kit, housing, gun, <i>includes 33a, 33b, 33c, 33d, 33e</i>
35	18H059	Kit, gun, complete, <i>includes 13, 14, 32, 33, 34, 36</i>
36	19F831	Screw, cross-head
37	18H126	Kit, solvent gasket (qty. 5), <i>includes removal/installation tool</i>
---	18H081	Kit, label, brand, Ultra (not shown)
---	18H082	Kit, label, brand, Ultimate (not shown)
* Battery and charger are dependent upon in country requirements.		
▲ Replacement safety labels, tags, and cards are available at no cost.		

NOTE: Gun 18H059 and Hose 2000354 are designed for use with the QuickShot sprayer only.

Pressure Relief Procedure

1. Turn Prime Knob up to PRIME position to relieve system pressure.

! WARNING



PRESSURIZED FLUID HAZARD

This sprayer builds up an internal pressure of 2000 psi (138 bar, 14 MPa) during use. Follow the **Pressure Relief Procedure** whenever you stop spraying and before cleaning, checking, servicing, or transporting equipment to prevent serious injury from pressurized fluid such as skin injection and splashing fluid.

PERSONAL PROTECTIVE EQUIPMENT

Wear appropriate protective equipment when in the work area to help prevent serious injury, including eye injury and inhalation of toxic fumes.

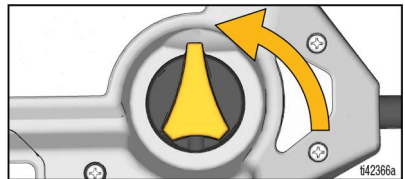

2. Hold metal tip guard nut firmly to a grounded metal pail. Point Spray Gun into pail, disengage Trigger Lock, and trigger the Spray Gun to relieve system pressure.

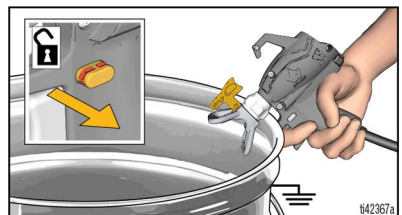

Enclosure Cover Removal

NOTICE

Do not use a power drill on the sprayer. Doing so can cause damage to the threads.

1. Perform **Pressure Relief Procedure**, page 4.
2. Remove battery (24) from sprayer.
3. Remove cup assembly (10).
4. Turn prime knob (12) forward to spray position.
5. Remove cross-head screw (21) from prime knob (12) and remove knob.

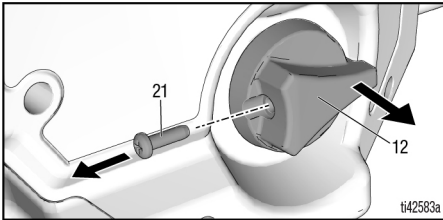

6. Remove five cross-head screws (20) from sprayer enclosure and remove enclosure cover (18).

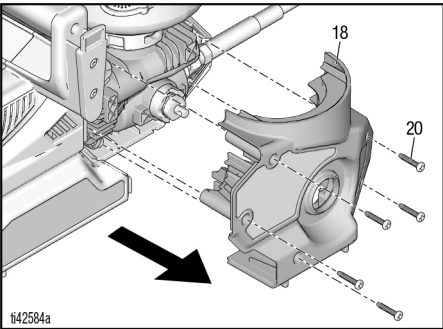

Enclosure Cover Replacement

1. Before installing enclosure cover, ensure wires are laid securely in wire channels, away from pinch points such as screw bosses and between the enclosure seam.

NOTICE

Failure to ensure wires are away from pinch points could cause the sprayer to become inoperable after assembled. Route the wires exactly as shown below.

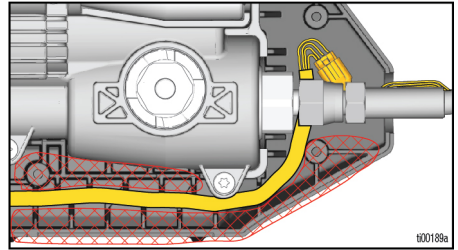

2. Install new enclosure cover (18). Secure with five cross-head screws (20). See **Assembly Drawing**, page 2, for torques.
3. Rotate prime valve stem so the valve stem cross hole is oriented front to back along the length of the sprayer.

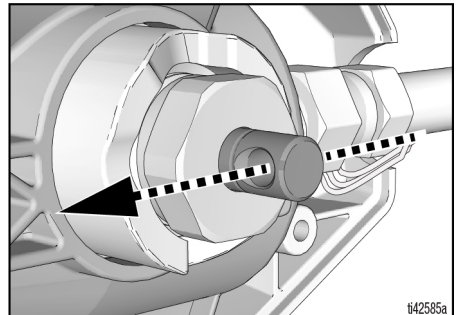

4. Install prime knob (12) so the knob is pointing forward. Install cross-head screw (21). See **Assembly Drawing**, page 2, for torques.

NOTE: The knob (12) will only rotate forward and up.

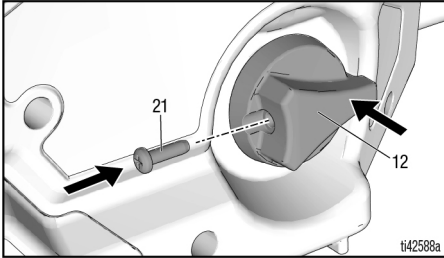

5. After assembly is complete, perform **Assembly Verification**, page 17.

Pump Assembly Replacement

NOTICE

Do not use a power drill on the sprayer. Doing so can cause damage to the threads.

1. Perform **Pressure Relief Procedure**, page 4.
2. Remove battery (24) from sprayer.
3. To replace the pump assembly (1) you must first remove the enclosure cover (18). See **Enclosure Cover Removal**, page 5.

4. Remove pump assembly (1) (with the hose) from SmartControl enclosure (6). Disconnect ground wire from pump assembly (1).

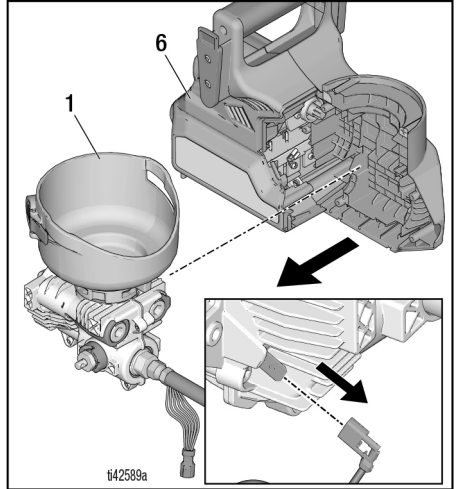

5. Disconnect electrical connectors. Remove hose (22) from hose adapter (15) using two wrenches.

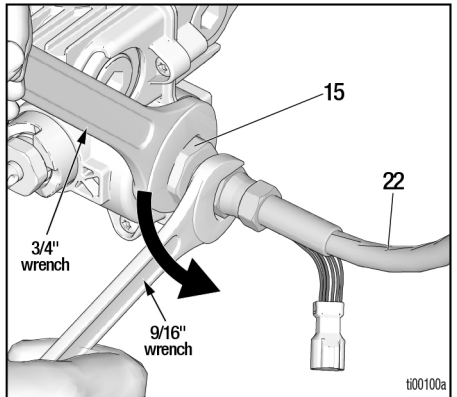

- Using same two wrenches, attach hose (22) to hose adapter (15) of new pump (1). Connect ground wire (A) to pump. Place new pump assembly (1) into SmartControl enclosure (6), while making sure the pump gear meshes with the motor gear.

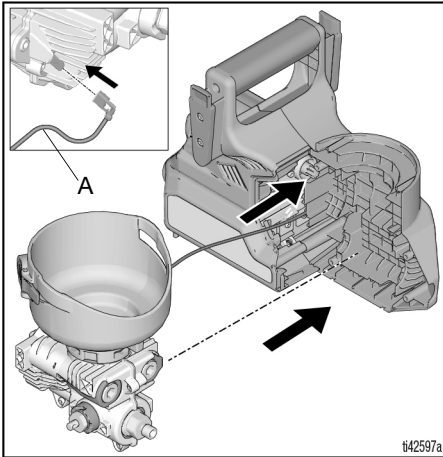

- Connect electrical connectors.

NOTE: Check to ensure all six pins are present, fully inserted, and straight inside the electrical connector on the hose before connecting. Then push the connectors together gently, while keeping the connectors parallel to each other, until they click together.

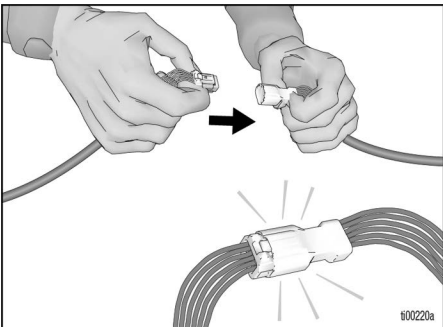

- To reinstall enclosure cover, see **Enclosure Cover Replacement**, page 5.

Prime/Spray Valve and Knob Replacement

NOTICE

Do not use a power drill on the sprayer. Doing so can cause damage to the threads.

- Perform **Pressure Relief Procedure**, page 4.
- Remove battery (24) from sprayer.
- Remove cross-head screw (21) from prime knob (12).

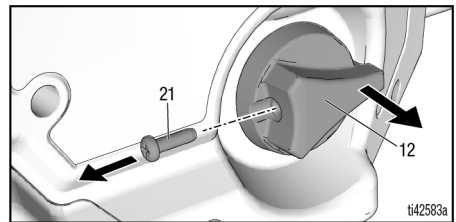

- Using a 5/8 in. (16mm) deep socket, remove prime/spray valve (4a) from pump assembly (1). Make certain o-ring is removed with the valve (4a).

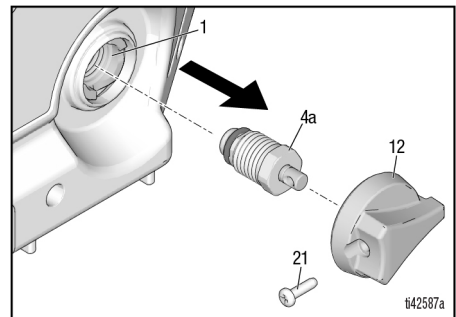

- Thread new prime/spray valve (4a) into pump assembly (1). See **Assembly Drawing**, page 2, for torques.

6. Rotate prime valve stem so the valve stem cross hole is oriented front to back along the length of the sprayer.

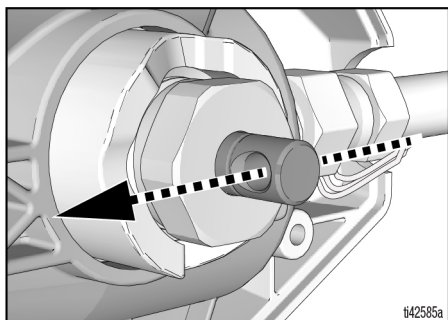

7. Install prime knob (12) so the knob is pointing forward. Install cross-head screw (21). See **Assembly Drawing**, page 2, for torques.

NOTE: The knob (12) will only rotate forward and up.

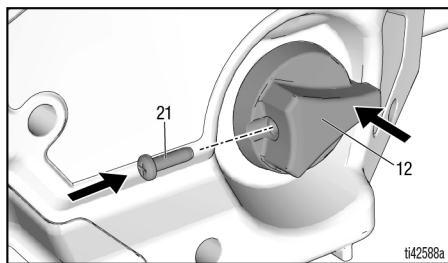

8. After assembly is complete, perform **Assembly Verification**, page 17.

Outlet Valve Replacement

NOTICE

Do not use a power drill on the sprayer. Doing so can cause damage to the threads.

1. Perform **Pressure Relief Procedure**, page 4.
2. Remove battery (24) from sprayer.
3. Remove enclosure cover (18). See **Enclosure Cover Removal**, page 5.
4. Remove pump assembly (1) from Sprayer Enclosure (6). See **Pump Assembly Replacement**, page 6, steps 1-5.
5. Remove two outlet valve plugs (3b) with 8mm (5/16") Allen wrench. Remove hose adapter (15) with 3/4" wrench. Remove three outlet valves (3a) and three o-rings (27) (may be stuck inside pump).

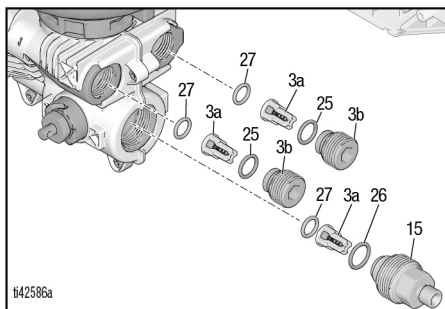

6. Separate the outlet valve assembly (3a) from the hose adapter (15). Save hose adapter for reuse.
7. Replace o-ring (26) on hose adapter (15).
8. Make certain new o-rings (25) are installed on the new outlet valve plugs (3b).

- Install new o-rings (27) into pump. Verify o-rings are flat against pump bushing. Use 8mm (5/16") Allen wrench to lightly push on the face of o-rings, if needed.

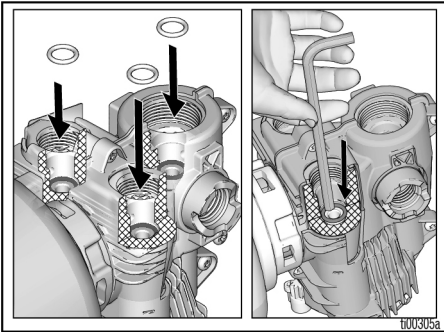

- Assemble new outlet valve assemblies (3a) into the outlet valve plugs (3b) and hose adapter (15).

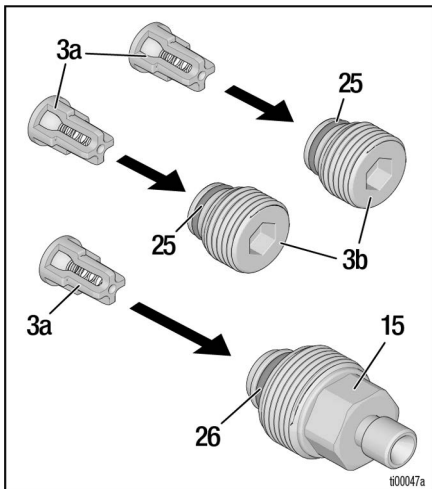

- Check balls should move freely against the spring in the retainers.
- Install two outlet valve plugs (3b) and hose adapter (15). Use 8mm (5/16") Allen wrench to install outlet valve plugs. Torque hose adapter to 60 in-lb. Torque outlet valve plugs until snug (20 in-lb).

NOTICE

Do not overtighten. Doing so can cause damage to the threads.

- Replace pump assembly, see **Pump Assembly Replacement**, page 6, steps 6-8.

SmartControl Enclosure Replacement

NOTICE

Do not use a power drill on the sprayer. Doing so can cause damage to the threads.

- Perform **Pressure Relief Procedure**, page 4.
- Remove battery (24) from sprayer.
- Remove enclosure cover (18). See **Enclosure Cover Removal**, page 5.
- Remove pump assembly (1) from SmartControl enclosure (6). See **Pump Assembly Replacement**, page 6, steps 1-4. Do not remove hose from pump.
- Replace pump assembly in new SmartControl Enclosure. Follow **Pump Assembly Replacement**, page 6, steps 6-8.

Hose Replacement

NOTICE

Do not use a power drill on the gun. Doing so can cause damage to the threads.

1. Perform **Pressure Relief Procedure**, page 4.
2. Remove battery (24) from sprayer.
3. Remove two cross-head screws (36) to open gun cover (34), and disconnect electrical connector.

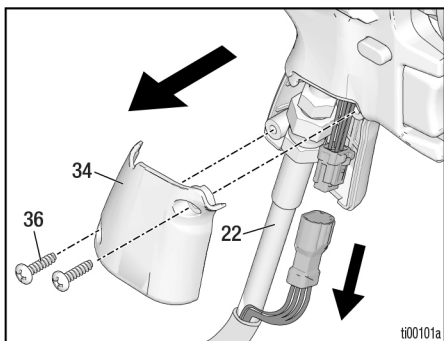

4. Using two wrenches, remove hose (22) from needle valve (32).

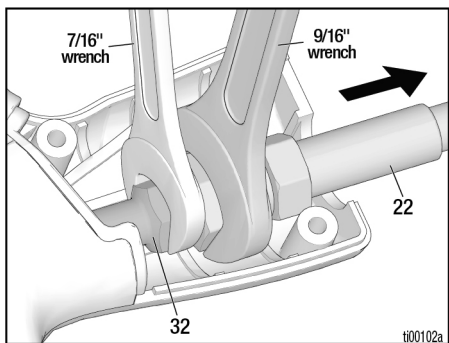

5. Remove enclosure cover (18). See **Enclosure Cover Removal**, page 5.

6. Disconnect electrical connector from Sprayer Enclosure (6).

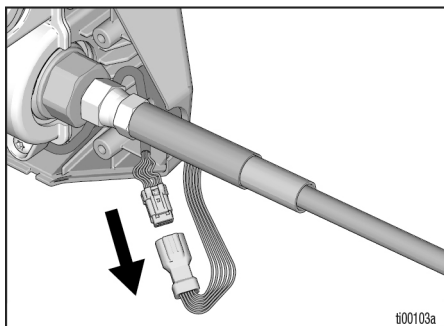

7. Using two wrenches, remove hose (22) from hose adapter (15).

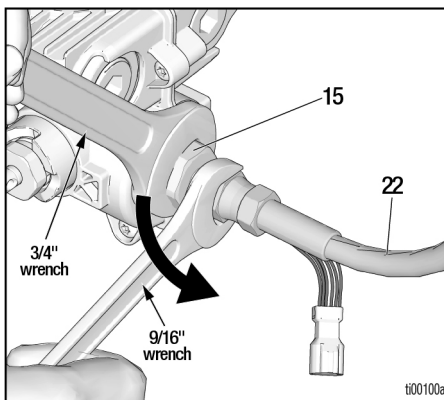

8. Using same wrenches, install new hose (22) to pump hose adapter (15) and gun needle valve (32).

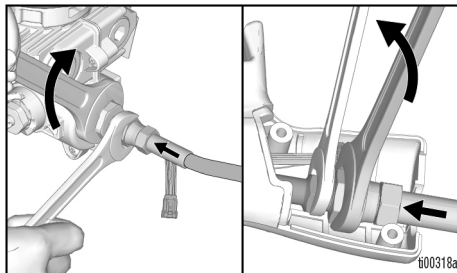

9. Connect electrical connectors at gun and pump.

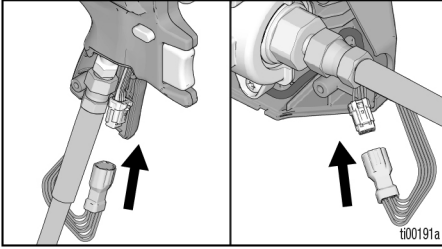

NOTE: Check to ensure all six pins are present, fully inserted, and straight inside the electrical connector on the hose before connecting. Then push the connectors together gently, while keeping the connectors parallel to each other, until they click together.

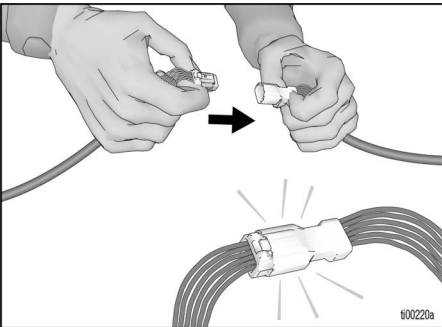

10. Install gun cover with cross-head screws (36). See **Assembly Drawing**, page 2, for torques.
11. To reinstall enclosure cover, see **Enclosure Cover Replacement**, page 5.

Spray Gun Parts Replacement

NOTICE

Do not use a power drill on the gun. Doing so can cause damage to the threads.

1. Perform **Pressure Relief Procedure**, page 4.
2. Remove battery (24) from sprayer.
3. Remove two cross-head screws (36) to open gun cover (34), and disconnect electrical connector.

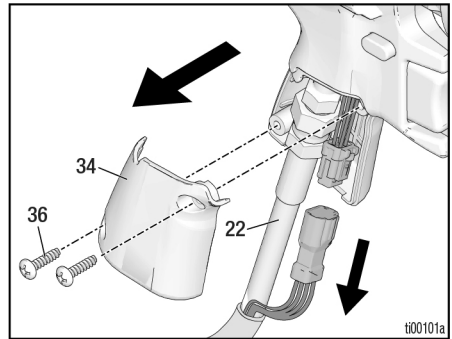

4. Using two wrenches, remove hose (22) from needle valve (32).

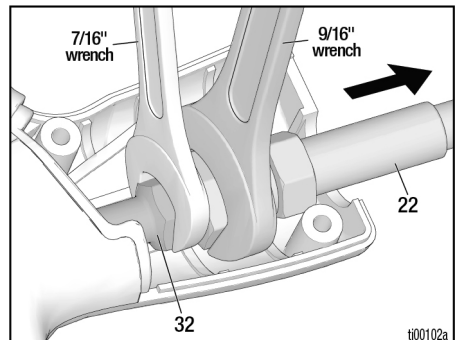

NOTE: If only replacing the Gun Housing Kit, skip steps 5-8.

- Remove four T15 torx screws (14) and one T10 torx screw (13) to open the gun housing. Separate the needle valve (32) and solenoid/ trigger assembly (33) by removing the set screw with a 1/16" Allen wrench. Thread them apart by hand. (See note below)

NOTE: If replacing the needle valve (32), keep the solenoid/trigger assembly (33) for reuse. If replacing the solenoid/trigger assembly (33), keep the needle valve (32) for reuse.

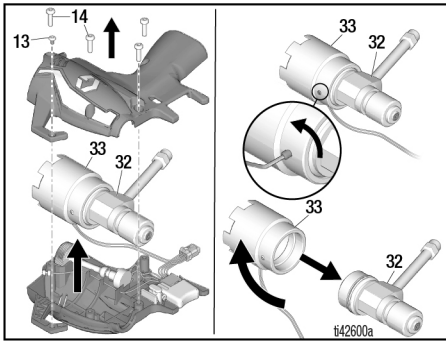

- Remove the solenoid washer that was inside the old assembly. Washer may be stuck inside solenoid of 33 or to the back side of 32. Place solenoid washer on to the back side of 32.

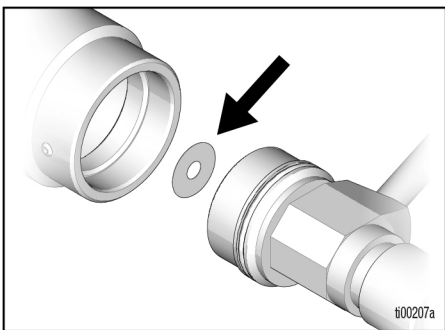

- Replace the new part (32 or 33) and thread back together by hand until bottomed out. **Then back out the thread by 1 to 1.25 revolutions.** This sets the needle stroke length.

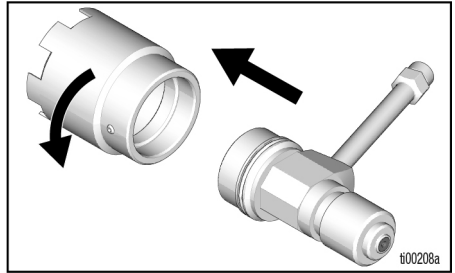

- Using a 1/16" Allen wrench, hand-tighten the set screws to lock the assembly in place.

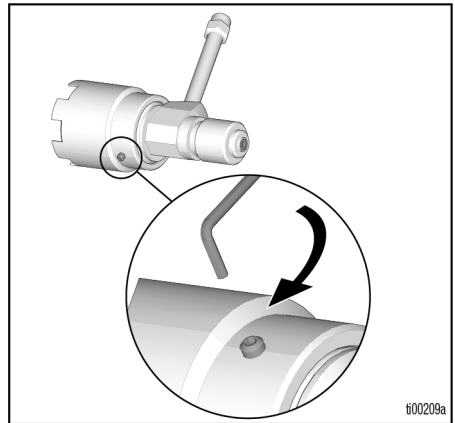

- Loosen the two nuts on the back plate of the solenoid/trigger assembly (33), then torque both nuts to 10 in-lbs to center the assembly to the needle valve (32).

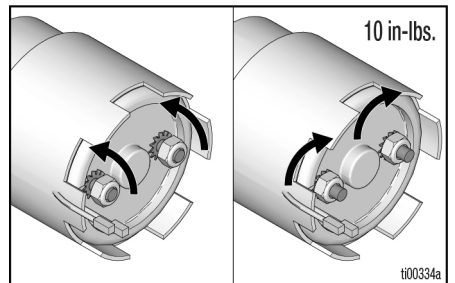

10. Reinstall the potentiometer, static wick, trigger, and trigger lock components as follows:

- a. Ensure adjustment knob (33e) is attached to the potentiometer.

NOTE: Alignment of #1 with the middle wire is critical. See image below.

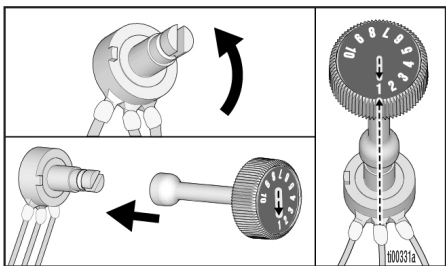

- b. Place needle valve assembly (32) into the smaller gun housing half. Ensure all wires are underneath the fluid tube, and the assembly is fully seated into the gun housing.

NOTE: The potentiometer wires should double back underneath the fluid tube as shown.

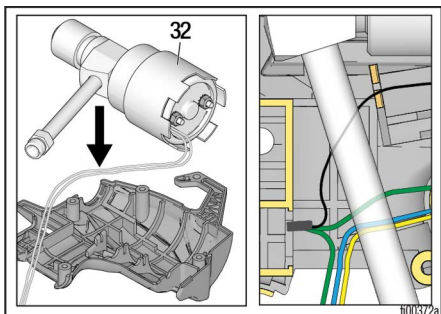

- c. Gently push the static wick wire (black) into the wire channels with a pencil eraser, then push the static wick into the small cutout in the back of the gun housing.

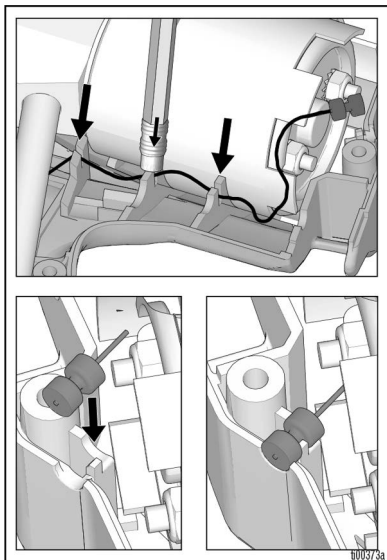

- d. Use a pencil eraser to push the white wires into the wire channels (on top of the black wire). Place adjustment knob assembly on the three grooves at the bottom of the gun housing.

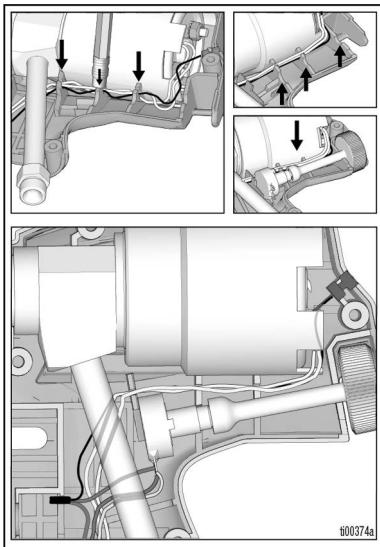

- e. Verify spring (33a) is on the trigger, then install the trigger lock (33c) into the trigger cap (33d), and place over the trigger. Push the trigger assembly into the gun housing as shown. Lastly, install the sliding plastic spring (33b).

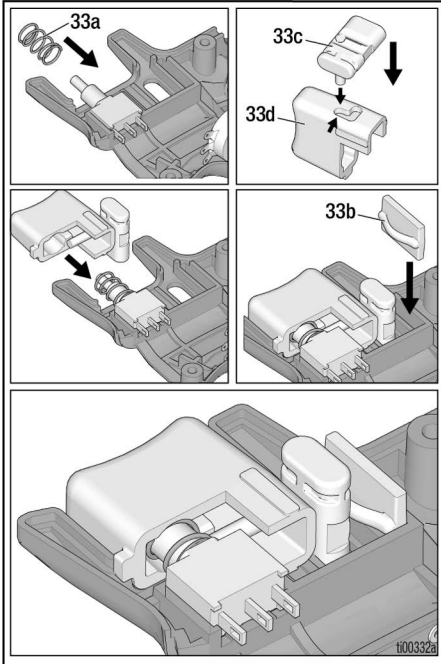

11. Double check all wires are laid securely in the wire channels and the static wick is in place, then reinstall the gun housing cover. Ensure housing cover snaps into place (around trigger components) before securing with four T15 torx screws (14) and one T10 torx screw (13).

NOTICE

Failure to ensure wires are away from pinch points could cause the sprayer to become inoperable after assembled. Route the wires exactly as shown below.

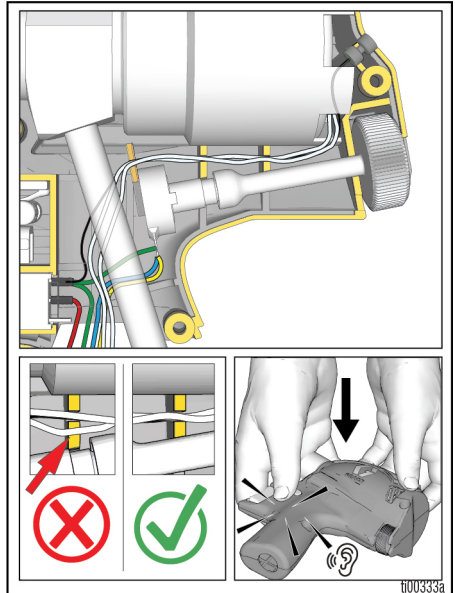

12. Using same two wrenches, install hose (22) to needle valve (32).

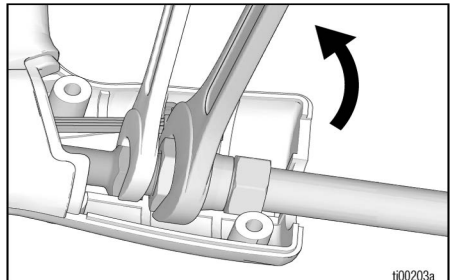

13. Connect electrical connector.

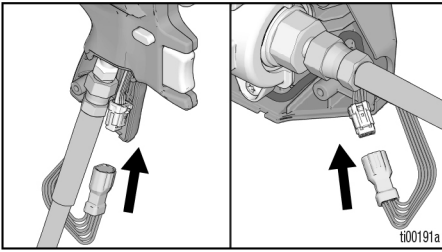

NOTE: Check to ensure all six pins are present, fully inserted, and straight inside the electrical connector on the hose before connecting. Then push the connectors together gently, while keeping the connectors parallel to each other, until they click together.

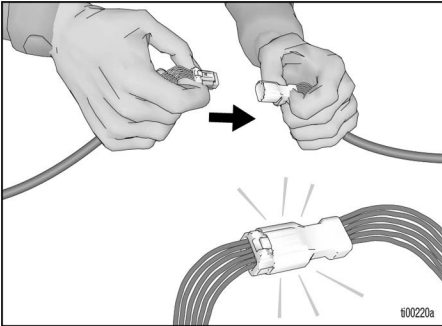

14. Install gun cover with cross-head screws (36). See **Assembly Drawing**, page 2, for torques.

15. After assembly is complete, perform **Assembly Verification**, page 17.

Solvent Gasket Removal/Replacement

1. Perform **Pressure Relief Procedure**, page 4.
2. Remove battery (24) from sprayer.
3. Remove tip guard (16).

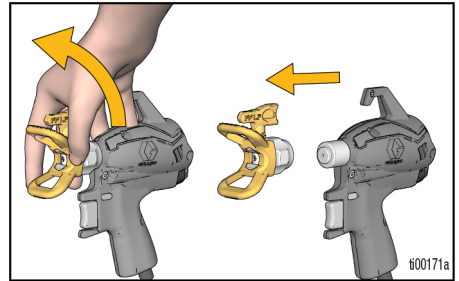

4. Apply pressure while threading solvent gasket removal tool into the worn gasket on the gun needle valve (32).

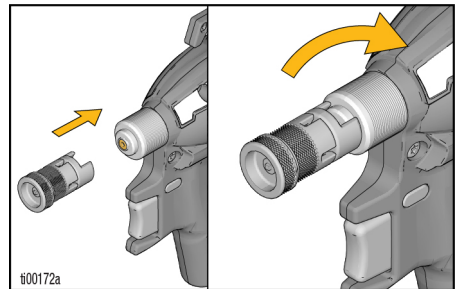

5. Once solvent gasket removal tool bottoms out on the gun face, continue threading tool into gasket until gasket is removed from the gun. Worn gasket will be threaded onto the tool.

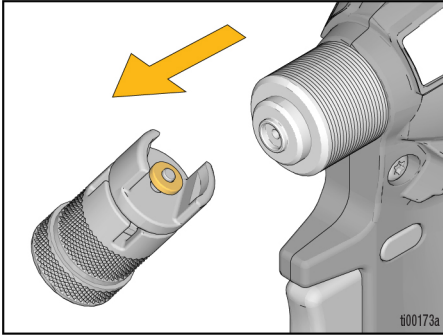

6. Use a pair of pliers to remove and discard worn gasket. Pinch gasket with pliers then unthread the tool until gasket pops off.

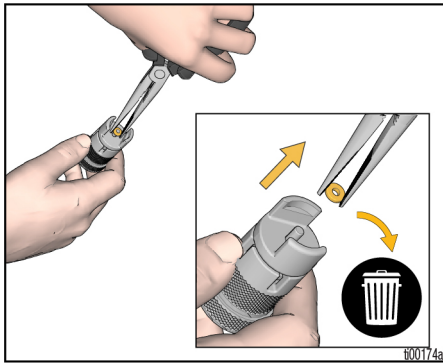

7. Place new solvent gasket (37) onto opposite side, non-threaded stud of the solvent gasket installation tool.

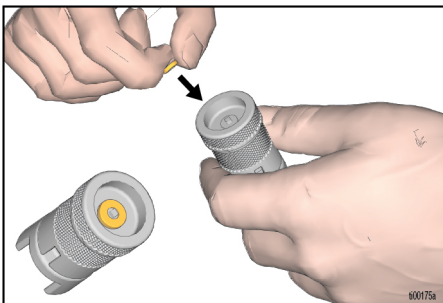

8. Assemble tool into the supplied nut.

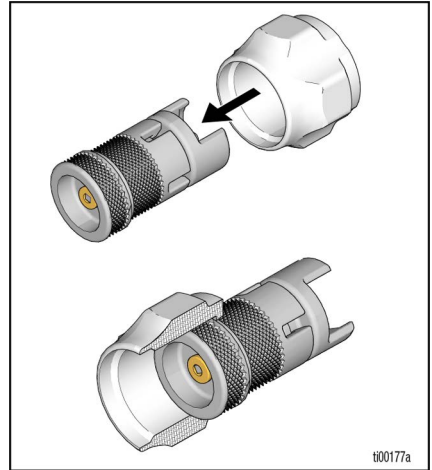

9. With installation tool, hand tighten the nut onto front of the gun. Continue to tighten until the nut has bottomed out.

NOTE: It is recommended to hold the installation tool below the gun so the gasket stays centered.

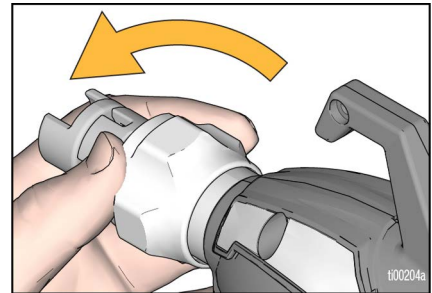

10. Remove nut and tool assembly from gun. Gasket (37) should be pressed into the gun needle valve (32).

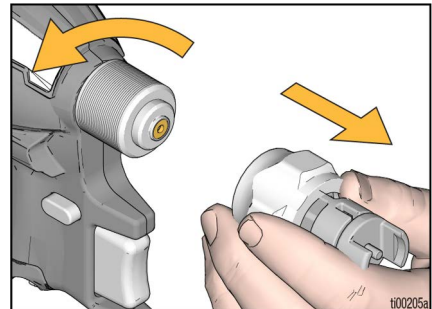

Assembly Verification

After assembly is complete, perform the following steps to verify proper operation. If sprayer fails one of the steps, repeat sprayer repair procedures.

- Rotate Prime Pump/Spray knob to make sure it rotates forward to the spray position and down to the prime pump position.
- Fill cup assembly (10) with water and verify sprayer primes and sprays. Follow setup instructions in sprayer operation manual for proper priming and spraying procedure.

California Proposition 65

CALIFORNIA RESIDENTS

 **WARNING:** Cancer and reproductive harm – www.P65warnings.ca.gov.

Graco Information

For the latest information about Graco products, visit www.graco.com.

For patent information, see www.graco.com/patents.

TO PLACE AN ORDER, contact your Graco distributor or call 1-888-541-9788 to identify the nearest distributor.

All written and visual data contained in this document reflects the latest product information available at the time of publication. Graco reserves the right to make changes at any time without notice.

Original instructions. This manual contains English. MM 3A9322

Graco Headquarters: Minneapolis

International Offices: Belgium, China, Japan, Korea

GRACO INC. AND SUBSIDIARIES • P.O. BOX 1441 • MINNEAPOLIS MN 55440-1441 • USA

Copyright 2023, Graco Inc. All Graco manufacturing locations are registered to ISO 9001.

www.graco.com

Revision B, April 2023